

### FEATURES

- RoHS compliant
- Primary current rating 15A<sup>3</sup>
- 50, 100 and 200 turn variants
- Frequency range 50kHz to 500kHz
- Surface mount
- Compact package
- UL94 V-0 package materials
- J-STD-020C reflow

### PRODUCT OVERVIEW

The 5400 series of current sense transformers are designed to monitor AC currents. The transformers can be used for high frequency current sensing in applications such as switched-mode power supplies, motor control, and electronic lighting ballasts.

### SELECTION GUIDE

Order Code	Turns Ratio	Min. Secondary Inductance (0.1V @ 10kHz)	Max. DC Resistance		Isolation Voltage <sup>1</sup> (Pri-Sec)	Terminating Resistance to produce 1V <sub>OUT</sub> /1A <sub>IN</sub>
		mH	Primary (1-6, 2-5) mΩ	Secondary (3-4) Ω		
<b>54050C</b>	1:1:50	3.8	7.0	0.5	1.2	50
<b>54100C</b>	1:1:100	14.8	7.0	3.2	1.2	100
<b>54200C</b>	1:1:200	60.0	7.0	6.6	1.2	200

### ABSOLUTE MAXIMUM RATINGS

Operating free air temperature range	-40°C to 125°C
Storage temperature range	-40°C to 150°C

### SOLDERING INFORMATION<sup>2</sup>

Peak reflow solder temperature	245°C
Pin finish	Tin
Moisture sensitivity level	1

### PACKAGE SPECIFICATIONS

#### Mechanical Dimensions

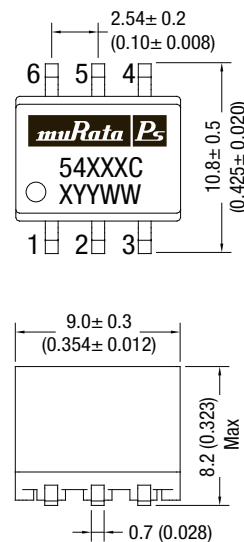

Unless otherwise stated, all dimensions in mm (inches) ±0.25 (0.010).  
Package weight 1.0g Typ.

#### Schematic

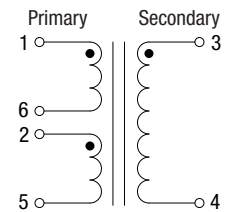

#### Recommended Footprint Details

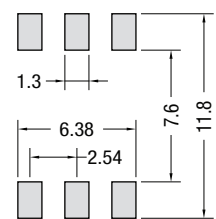

All specifications typical at T<sub>a</sub>=25°C

1. Flash tested for 1 second.
2. For further information, please visit [www.murata-ps.com/rohs](http://www.murata-ps.com/rohs)
3. Primary windings connected in parallel.



**PACKAGE SPECIFICATIONS**

**Mechanical Dimensions**

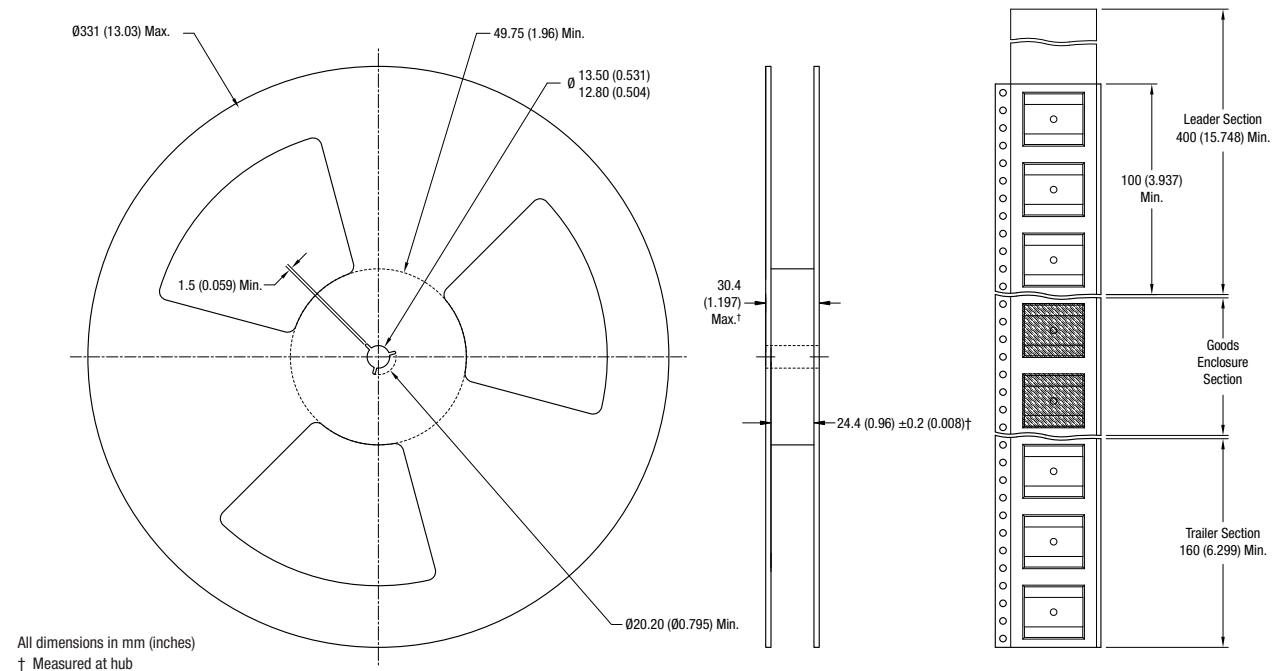

**Tape Outline Dimensions**

